

# Cima FF

Fixed Frame, Snap Screens



**Stewart**  
F I L M S C R E E N

The Reference for Stunning™

Printed in the USA. ©2022 Stewart Filmscreen Corporation

Stewart Filmscreen reserves the right to make changes to the product specified in this document.

Sizes and specifications are subject to change without notice at Stewart's discretion. From time to time, this document is updated. Current versions of this documentation are posted on the Stewart Filmscreen website at:

[www.StewartFilmscreen.com](http://www.StewartFilmscreen.com)

Revision 1.01.02

Date: 04/26/2022

# Cima FF

OWNER'S MANUAL

## Contents

To the Owner	4
About Cima FF	5
Preparing the Installation	6
Frame Assembly Instructions	8
Hanging Bar Mount	9
Attaching the Screen to the Frame	12
Caring for and Cleaning the Screen	14
One (1) Year Limited Warranty	15

---

## **TO THE OWNER**

---

Congratulations on purchasing one of the finest optical viewing screens in the world.

Your handcrafted, Cima FF projection screen has been carefully inspected to ensure you will have an optimal viewing experience that will last many years. Please take a moment to review this manual. It will guide you through the installation and the operation of your screen and will also provide you with detailed instructions on how to care for your screen's viewing surface.

From all of us at Stewart Filmscreen, we would like to thank you for choosing Cima FF. Should you have any questions, please don't hesitate to contact our customer service department at 1 (310) 784-5300, or toll free at 1 (800) 762-4999. We're here to help.

A handwritten signature in black ink, appearing to read "Frank Gomez". The signature is fluid and cursive, with a long horizontal stroke at the end.

Frank Gomez  
Fixed Frame Masking Specialist

## **ABOUT CIMA FF**

---

Your Cima FF fixed frame supports virtually all projection applications. The Velux finish is designed to absorb any projector overscan. The Cima FF features angled corners and a beveled edge that brings the image area closer to the front of the frame.

The Cima FF features snaps and brackets that move on the frame to allow for adjustments. Rear projection is available as an option. The hanging bar is the standard mount.

### **USING THIS MANUAL FOR INSTALLATION**

The Cima FF screen is designed for easy installation. There are no user-serviceable parts contained within the unit.

### **VOIDING YOUR WARRANTY**

**NOTE: Failure to comply with the instructions and guidance contained in this manual may result in voiding your warranty.**

For the instructions related to your specific mount type, refer to the appropriate page:

- Hanging Bar Mount (page 9)

At the designated point in the installation, you will need to refer to the general instructions for: **Attaching the Screen to the Frame (page 12-13).**

# **PREPARING THE INSTALLATION**

---

Before proceeding with the installation, take the time to thoroughly read and understand these installation instructions. Failure to comply with the instructions and guidance contained in this manual may result in voiding your warranty.

## **SPECIFICATIONS**

Specifications regarding the individual screen dimensions, weight, etc., are provided by the factory when the unit is ordered.

Before beginning the installation

- ▶ Make sure there is a clean surface to unroll the screen and assemble the frame.
- ▶ Check the size and weight of the screen to be installed so that you can plan for the number of people required for installation. You need at least two people to mount the smaller screens. More people are needed for larger, heavier screens.

What's inside the box?

Inside your Cima FF unit box, you will find everything you need to get started on enjoying your Stewart screen:

- ▶ Screen image rolled up in a tube
- ▶ Disassembled frame with all the hardware needed to reassemble
- ▶ Packing material
- ▶ Quick Start Guide

You will need:

- ▶ A drill
- ▶ A level
- ▶ A drop cloth
- ▶ Tools for tightening fasteners
- ▶ Lint-free, clean cloth gloves for handling the screen
- ▶ Fasteners appropriate for the surface on which the screen is being mounted
- ▶ Ladders for the personnel supporting the screen during the mounting process

## **PREPARING THE INSTALLATION (CONTINUED)**

---

Note: Bolts and other fasteners for the screen are standard gauge and standard sizes used in the U.S., regardless of the installation country. For this reason, sizes are in inches rather than metric measurements.

### **UNPACKING**

Be sure to unpack carefully in a clean area. Use special care when handling the screen so that it does not become soiled or damaged. If you plan to repack your screen and hardware for transportation to another location, you may wish to photograph or make a note of how it was packed. Retain the packing material for future use, if desired.

### **CAUTION**

Do not stand on the screen tube or store it on its end. This will cause screen damage. If you are not planning to install the screen immediately, make sure it remains horizontal during storage.

# FRAME ASSEMBLY INSTRUCTIONS

1. Connect the frame members by matching the numbered dots on the ends of the members.
2. Secure the frame members with the supplied 5/16-18 x 1/2" hex head bolts (see Figure 1).

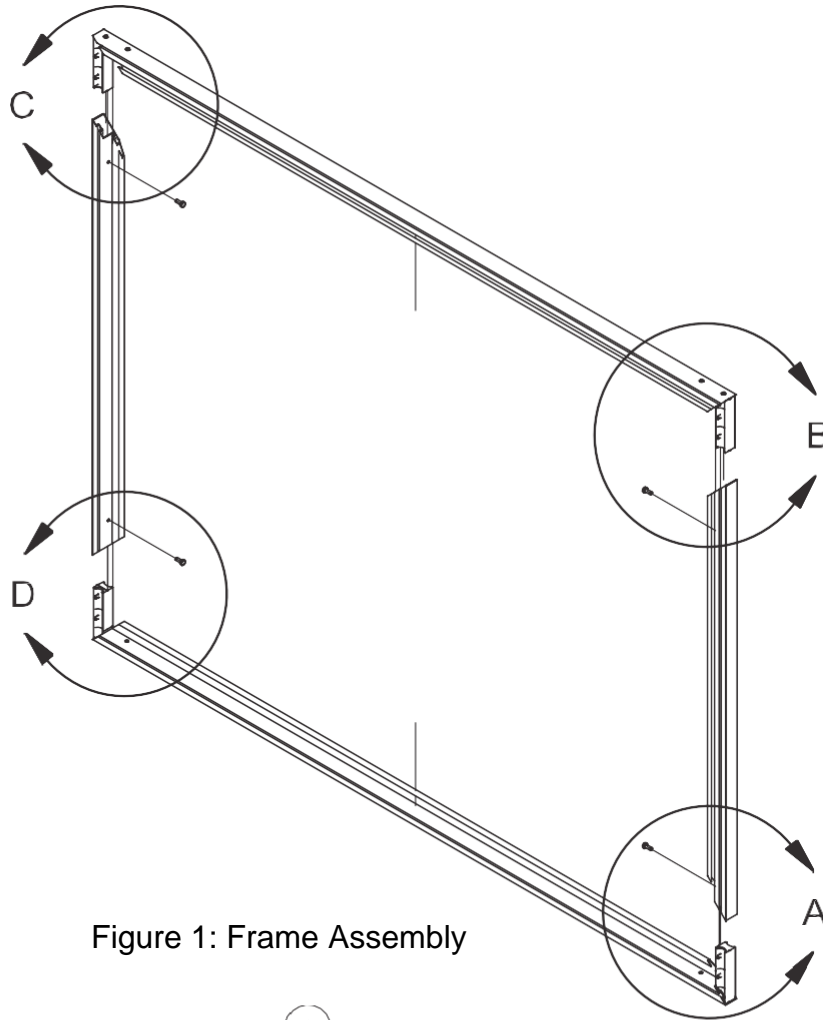
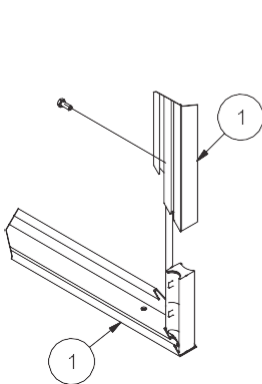
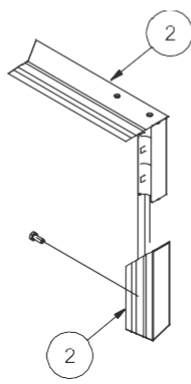

Figure 1: Frame Assembly



**DETAIL A**  
AUD. LEFT BOTTOM CORNER



**DETAIL B**  
AUD. LEFT TOP CORNER

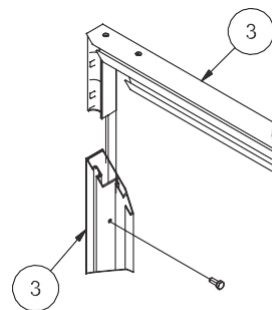

**DETAIL C**  
AUD. RIGHT TOP CORNER

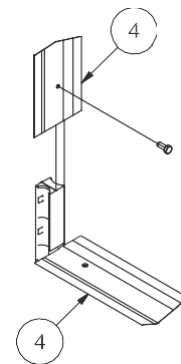

**DETAIL D**  
AUD. RIGHT BOTTOM CORNER



# HANGING BAR MOUNT

---

**NOTE: Professional mounting techniques should be used. Stewart Filmscreen cannot be liable for substandard or faulty installations. Failure to comply with the instructions and guidance contained in this manual may result in voiding your warranty.**

## **⚠ CAUTION**

- Be careful not to touch or scratch the viewing surface.

To accurately position the frame, mount the hanging bar and temporarily hang the frame before attaching the screen material. On the bottom of the frame, there are magnets you can slide to line up the steel pucks with wall studs. If the wall is not perfectly flat, the force of the magnet may cause the frame to bend. For this reason, shims can be placed between the wall and steel pucks so that the frame remains straight. The screen should not be attached to the frame at this point (see Figures 3-6).

1. Identify the location of wall studs where you can securely mount the hanging bar.
2. Use a level to accurately position the hanging bar on the wall (see Figure 2).
3. Drill holes through the bar into the studs.
4. Use the provided screws or other appropriate fasteners to secure the hanging bar to the wall studs.



Figure 2: Hanging bar Level and on Wall Studs

- Note: A minimum of three (3) screws are recommended to safely secure the frame. More screws are needed for heavier screens.
5. Recheck to make sure the bar is level.
  6. Hang the assembled frame, without the screen attached, on the hanging bar to ensure that it is correctly mounted.
  7. Mark the wall where you will mount the steel pucks to studs that will align with the magnets fastened on the frame.  
**Note:** Find studs that allow the pucks and magnets to be positioned approximately 12" to 24" from the edge of the frame on each side.
  8. Remove the frame. Drill into the studs and mount the steel pucks with the provided 2-3/8" screws or other appropriate fasteners. Use shims as needed.

## HANGING BAR MOUNT (CONTINUED)

9. Reposition the frame and the slide, and then secure the magnets so they align with the steel pucks mounted on the wall.
10. Remove the frame. Follow the steps for attaching the screen to the frame (pages 12-13). However, do not attach the snaps of the bottom row at this moment.
11. Lift the frame with the bottom row of the screen unattached, and attach the back brace to the frame between two snaps near the center with the provided screws or other appropriate fastener (See figure 5)
12. Attach the snaps of the bottom row (page 12).
13. Your Cima FF is now ready to hang in its final position (see Figures 6-8).

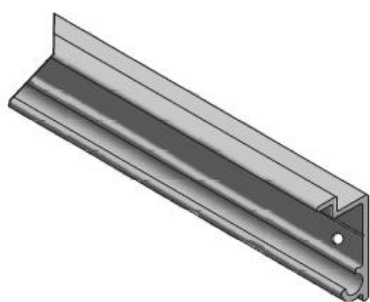

Figure 3: Hanging Bar Front View

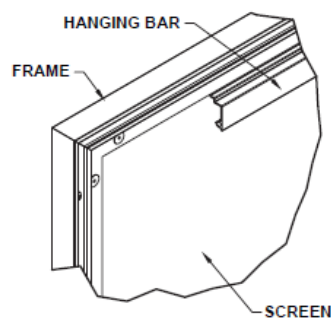

Figure 4: Screen Rear View

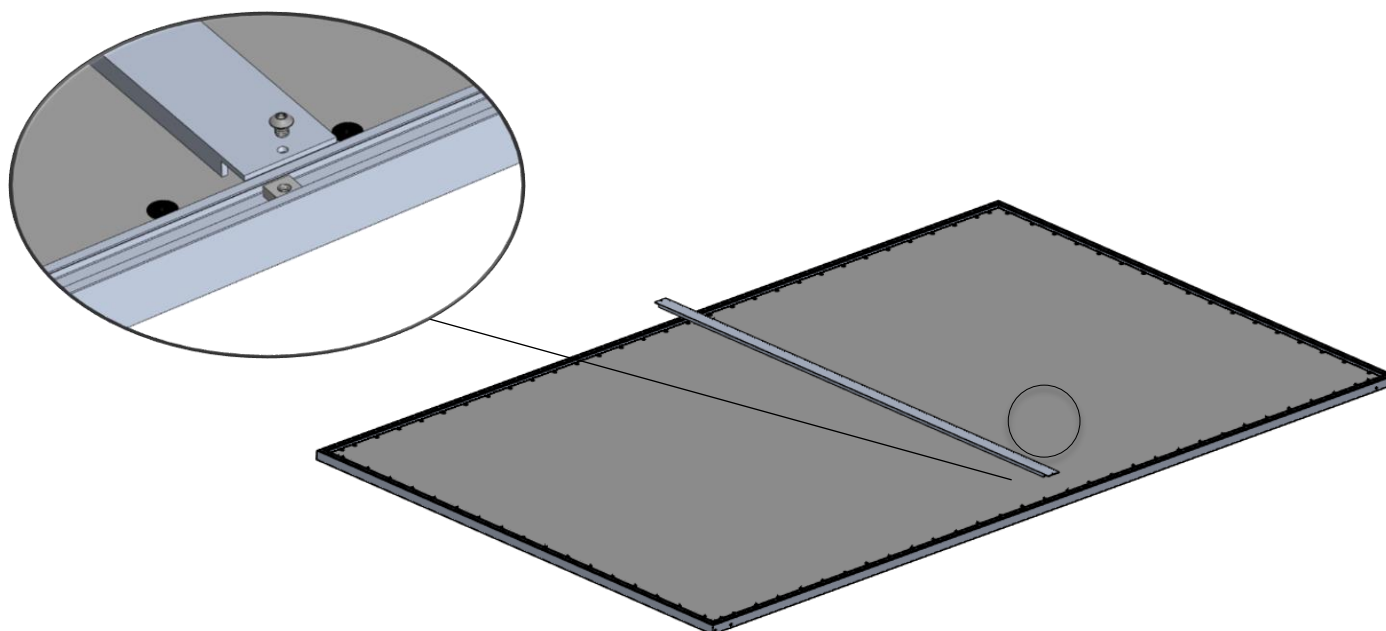

Figure 5: Attaching Back Brace to the Frame

# HANGING BAR MOUNT (CONTINUED)

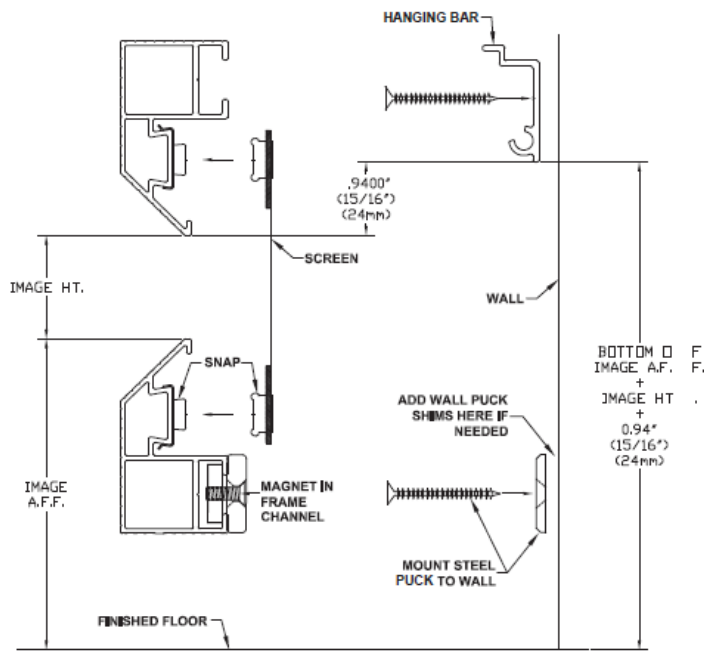

Figure 6: Components for Wall Mounting – Side view

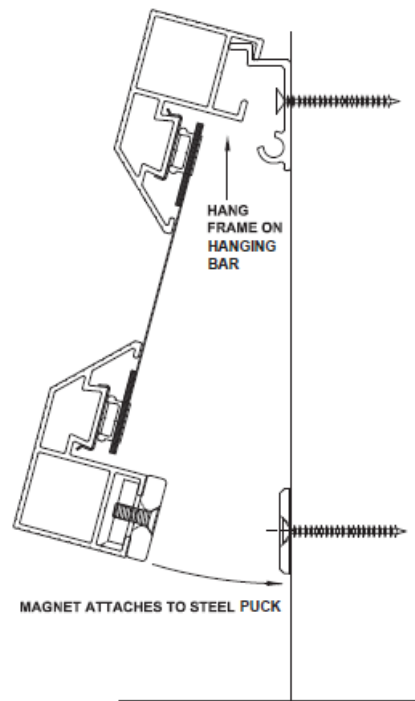

Figure 7: Hanging the Screen – Side View

## Hanging Bar Mount

16 inch Preset position – 18 inch wall bar for screen under 108 inch width. 33.5 inch wall bar for screens over 108 inch width

## Hanging Bar Mount

16 inch Preset position – 18 inch wall bar for screen under 108 inch width. 33.5 inch wall bar for screens over 108 inch width

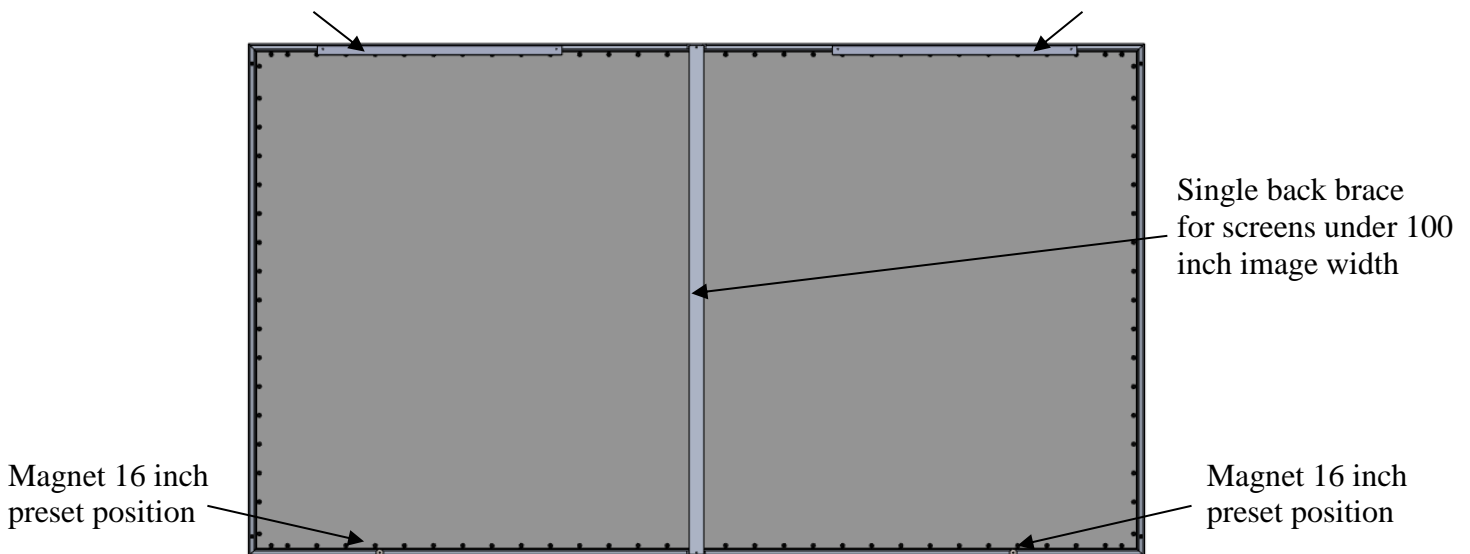

Figure 8: Cima FF with Back Brace and Fitted Hanging Bar Mount – Rear View

## **ATTACHING THE SCREEN TO THE FRAME**

**DO NOT** perform this step **UNTIL** instructed to do so in the mounting section.

### **⚠ CAUTION**

- Be careful not to touch or scratch the viewing surface.
- Do not use any tools to fasten the screen to the frame.
- Do not fold or crease the screen.

### **UNPACKING AND UNROLLING THE SCREEN**

The viewing side of the projection screen is rolled to the inside to protect optical quality. The screen is rolled lengthwise.

1. Remove the screen from the cardboard shipping tube.
2. On a clean surface, unroll the screen viewing side up (see Figure 9).
3. Remove the protective packing material from the screen material.

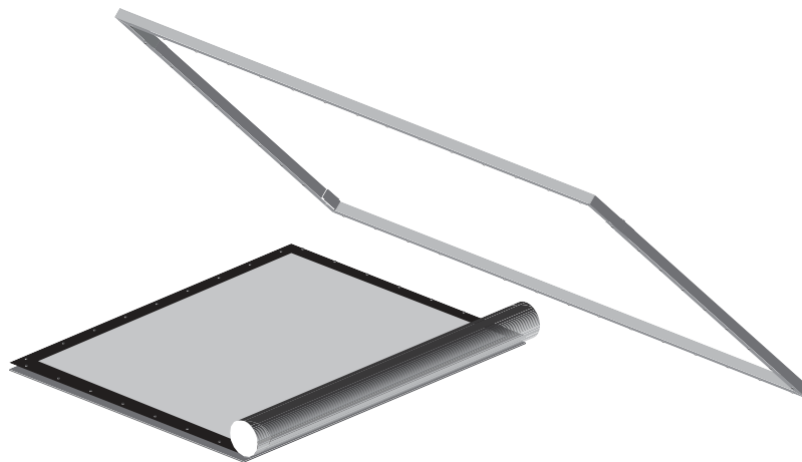

Figure 9: Unrolling the Screen

## **ATTACHING THE SCREEN TO THE FRAME (CONTINUED)**

4. Place the frame over the screen, snap side down (see Figure 9).
5. Starting with the snaps on the top corners and then horizontally along the top while lifting the frame with one hand, snap the screen into the frame. Gently allow the screen to stretch onto the snaps. Do not jerk, wrinkle, or crease the screen material, as it can be damaged (see Figure 10).
6. Lift the frame to a vertical position to finish attaching the sides and bottom row of the snaps (see Figure 11).

Note: If there are any wrinkles or puckers on the screen, the snaps on the frame can be adjusted side to side. Lay the frame viewing side down on a clean surface. A movement of 1/16" to 1/8" (1.6mm to 3.2mm) is usually sufficient to eliminate puckers.

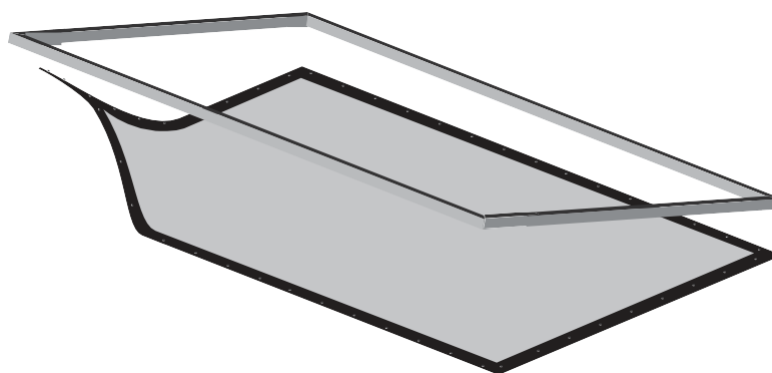

Figure 10: Attaching Top Corner Snaps

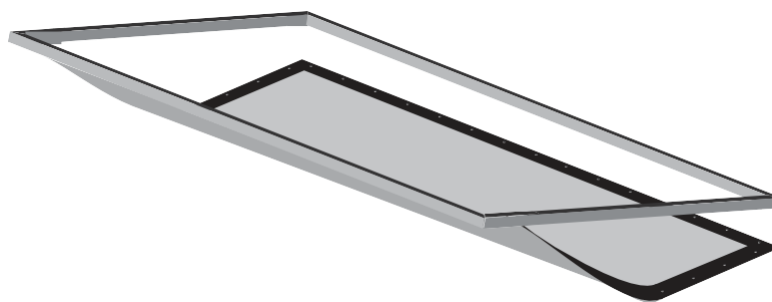

Figure 11: Attaching Remaining Snaps

# **CARING FOR AND CLEANING THE SCREEN**

---

## **GENERAL MAINTENANCE**

With reasonable care, you may expect many years of dependable use of your Stewart projection screen.

## **FOR VINYL SCREEN MATERIALS ONLY**

The surface of your screen is delicate, so we encourage you to keep your screen clean. Special attention to these instructions should be followed when cleaning.

- ▶ Avoid getting any foreign objects on the screen, as cleaning may prove very difficult. It may not be possible to remove scratches, paint, ink, etc.
- ▶ A draftsman-style brush may be used to lightly whisk away any loose dirt or dust particles. (This type of brush is usually available at office supply stores.)
- ▶ For tougher spots, you can make a cleaning solution using a water-based detergent and warm water. To make the solution, mix one-part Simple Green, 409, or another water-based industrial cleaner with three parts warm water. Moisten a clean cotton cloth, or cotton swab with this solution, moisten the stained area, and gently lift off the stain. Never use an aggressive scrubbing action as you could damage the screen surface by removing the optical coating. Re-moisten the area with clean water and dab dry with a clean sponge or cotton cloth. Any residual watermarks will evaporate on their own in a few minutes.
- ▶ Contact tech support at Stewart Filmscreen if you have questions about removing difficult spots.

### **⚠ CAUTION**

- ▶ Do not use any other cleaning materials on the screen.
- ▶ Do not use chemicals, solvents, or alcohol-based cleaners to clean the screen. Use only commercially available, water-based degreaser or liquid dish soap.
- ▶ Do not use chemicals, solvents, or liquid cleaners to clean the Velux covering.
- ▶ Do not fold or crease the screen.

## **VELUX™ COVERING**

- ▶ Use a lint roller to remove particles from the Velux, which is the material covering the frame.
- ▶ A brush may be used to comb (lift) the nap of the Velux material to eliminate depression marks.

## **FOR NON-VINYL SCREEN MATERIAL**

If you have concerns with one of our non-vinyl Stewart Filmscreen screen materials, contact tech support at Stewart Filmscreen.

## **ONE (1) YEAR LIMITED WARRANTY**

---

STEWART FILMSCREEN CORPORATION (Stewart) warrants all products to the original purchaser only. Stewart products are guaranteed to be free from defects in materials and workmanship for a period of one (1) year from the date of purchase by the original purchaser or eighteen (18) months from date of manufacture, as defined in the serial number. Additionally, all products must be properly operated and maintained according to Stewart instructions and cannot be damaged due to improper handling or treatment after shipment from the factory. This warranty does not apply to equipment showing evidence of misuse, abuse, or accidental damage, including neglect caused by improper installation (i.e. proximity to hot lights, exposure to extreme heat or cold, exposure to excessive humidity, etc.).

Stewart on-site warranty repair services are not available for this product. Stewart's sole obligation under this warranty shall be to repair or to replace (at Stewart's sole discretion) the defective part of the merchandise. This warranty expressly does not cover any costs of removal, installation, framing, or other costs incidental to replacing the screen or returning it to Stewart. Returns for service should be made to your Stewart dealer. If it is necessary for the dealer to return the screen or part to Stewart, transportation (freight) expenses to and from Stewart are payable by the purchaser. Stewart is not responsible for damage in shipment. To protect against damage or loss in transit, insure the product and prepay all transportation expenses.

This warranty is in lieu of all other warranties, expressed or implied, including warranties as to fitness for use or merchantability. Any implied warranties of fitness for use, or merchantability, that may be mandated by statute or rule of law are limited to the one (1) year warranty period. This warranty gives you specific legal rights, and you may also have other rights which vary from state to state. In no event will Stewart be liable for sums in excess of the purchase price of the product. No liability is assumed by Stewart for expenses or damages resulting from interruption in operation of equipment, or for incidental, direct, or consequential damages of any nature. In the event that there is a defect in materials or workmanship of a Stewart Filmscreen product, you may contact our Customer Service Department at 1161 W Sepulveda Blvd, Torrance, CA 90502- 2797, or call us at 1 (310) 784-5300, or toll free at 1 (800) 762-4999.

**IMPORTANT:** This warranty shall not be valid and Stewart shall not be bound by this warranty if the product is not operated and maintained in accordance with Stewart's written instructions. Stewart Filmscreen Corporation shall not be liable for any and all consequential damage(s) occasioned by the breach of any written or implied warranty pertaining to the sale of a Stewart Filmscreen product in excess of the purchase price of the product sold.



The Reference for Stunning™

[www.StewartFilmscreen.com](http://www.StewartFilmscreen.com)

1161 W. Sepulveda Blvd., Torrance CA 90502 USA | 1 (800) 762-4999 | Tel: 1 (310) 784-5300 | Fax: 1 (310) 326-6870

Email: [TechSupport@StewartFilmscreen.com](mailto:TechSupport@StewartFilmscreen.com)

©2022 Stewart Filmscreen. Specifications are subject to change without notice.